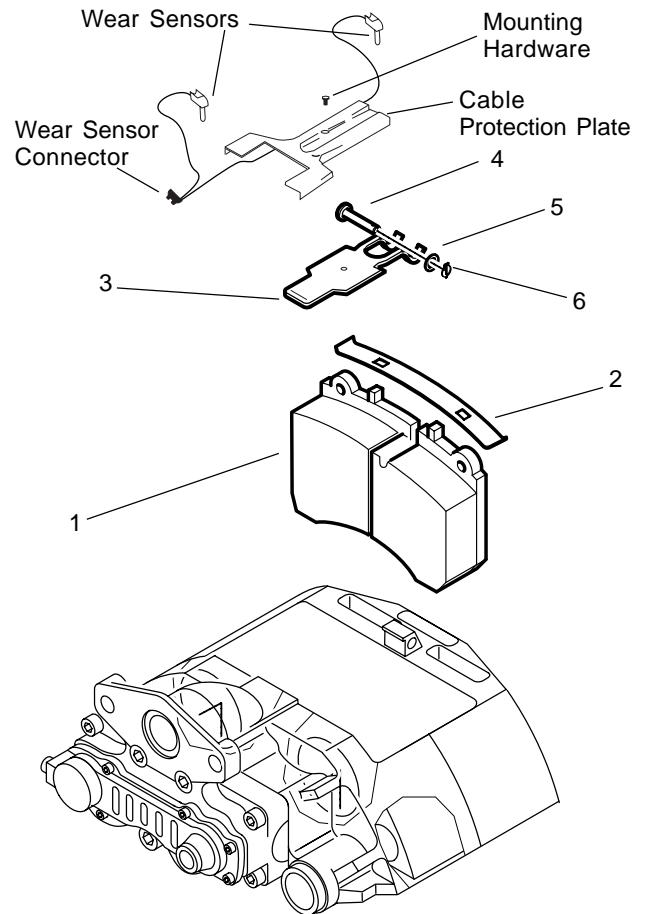




# Installation Instructions

## Complete Axle Brake Pad Replacement Kit for SB-7 Air Disc Brakes

Key	Description	Qty.
1	Brake Pads	4
2	Pad Retaining Spring	4
3	Brake Pad Hold Down Bar	2
4	Hold Down Bar Pin	2
5	Washer	2
6	Pin Retention Clip	2
Not shown	Adjuster Caps	4
Not shown	Brake Adjuster Adapter	1



**IMPORTANT! PLEASE READ AND FOLLOW THESE INSTRUCTIONS TO AVOID PERSONAL INJURY OR DEATH:**

**When working on or around a vehicle, the following general precautions should be observed at all times.**

1. Park the vehicle on a level surface, apply the parking brakes, and always block the wheels.
2. Stop the engine when working around the vehicle.
3. Make certain to drain the air pressure from all reservoirs before beginning ANY work on the vehicle.
4. Following the vehicle manufacturer's recommended procedures, deactivate the electrical system in manner that removes all electrical power from the vehicle.
5. When working in the engine compartment the engine should be shut off. Where circumstances require that the engine be in operation, EXTREME CAUTION should be used to prevent personal injury resulting from contact with moving, rotating, leaking, heated, or electrically charged components.
6. Never connect or disconnect a hose or line containing pressure; it may whip. Never remove a component or plug unless you are certain all system pressure has been depleted.
7. Never exceed recommended pressures and always wear safety glasses.
8. Do not attempt to install, remove, disassemble or assemble a component until you have read and thoroughly understand the recommended procedures. Use only the proper tools and observe all precautions pertaining to use of those tools.
9. Use only genuine Bendix® replacement parts, components, and kits. Replacement hardware, tubing, hose, fittings, etc. should be of equivalent size, type, and strength as original equipment and be designed specifically for such applications and systems.

**Figure 1 - Air Disc Brake Components**

10. Components with stripped threads or damaged parts should be replaced rather than repaired. Repairs requiring machining or welding should not be attempted unless specifically approved and stated by the vehicle or component manufacturer.
11. Prior to returning the vehicle to service, make certain all components and systems are restored to their proper operating condition.

### PREPARATION

1. Follow all safety precautions outlined above, including park vehicle on a level surface and block wheels.
2. **Important: If equipped with spring brakes, cage the spring brakes on all axles to be worked on.** Consult vehicle manufacturer's instructions as necessary.

3. Raise the complete axle to be worked on until the tires clear the ground. Remove wheels using the procedures specified in the vehicle maintenance manual.

## DESCRIPTION

The Bendix® Air Disc Brake System uses a floating caliper design to provide foundation braking on all axles of heavy commercial vehicles and trailers. When compared to traditional S-cam brakes, the Bendix Air Disc Brake System provides enhanced safety and performance, and is easier to service. The Bendix Air Disc Brake System is available in models with or without a combination spring brake unit. Optional wear sensors and wear diagnostic equipment are available on some models.

## BRAKE ADJUSTMENT

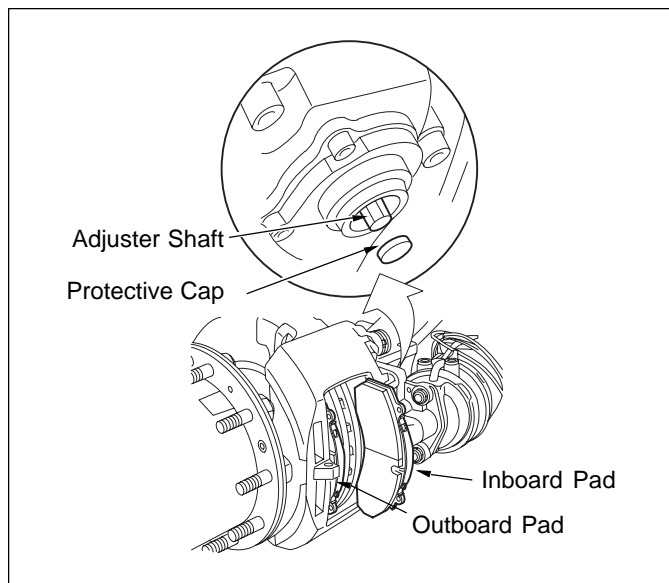
The caliper contains a brake adjuster mechanism that turns threaded tubes to set a gap (running clearance) between the rotor and the brake pads. When operated manually with the adjuster shaft, the adjuster mechanism sets the system's non-braked position. The adjuster mechanism also operates automatically, whenever the brakes are activated, to compensate for rotor and brake pad wear and keep the running clearance constant.

## DISASSEMBLY

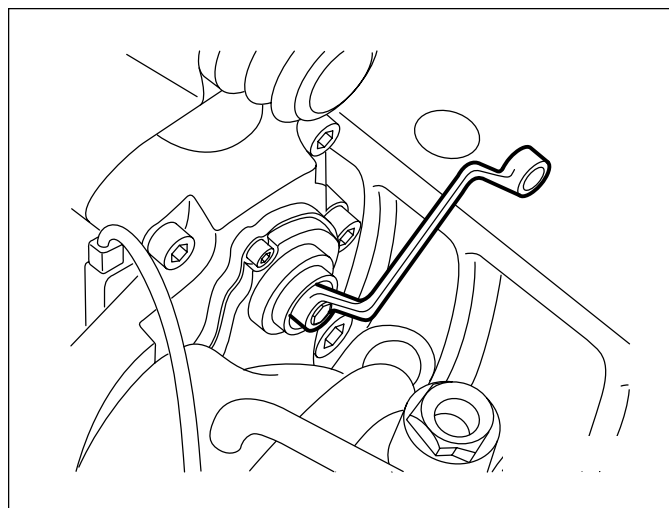
1. If the air disc brake is equipped with clip sensor wear indicator (see Figure 1), remove and retain the mounting hardware for the cable protection plate. The cable protection plate can then be set aside while servicing the pads. Note the position of the sensors in the brake pad channels, and carefully remove them. In most cases you do not need to release the cable connector in order to move the sensors away from the pad installation work area. Inspect the wear sensors - replace if damaged or abraded.
2. Remove and discard the pin retention clip(6) and washer(5).
3. While pressing against the pad hold down bar, remove the hold down bar pin(4). Discard hold down bar.
4. Remove adjuster cap to expose adjuster shaft (Figure 2). Note type of cap used.
5. Inspect adjuster shaft adapter. If significant corrosion and or damage is present, remove the adjuster adapter using needle-nose pliers and replace with the adapter supplied in the kit.

## CAUTION!

**Avoid overloading or damaging the adjuster shaft. The recommended tool is an 8 mm six-point box wrench. Do not use an open-ended wrench since it may damage the adjuster shaft.**

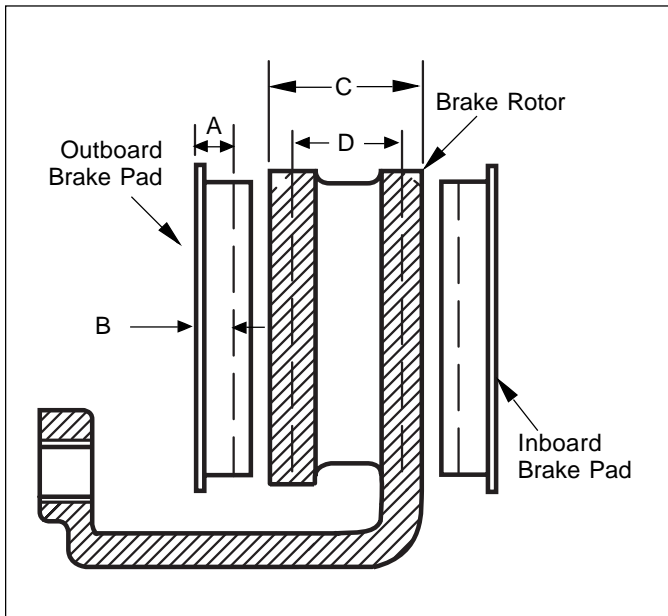


**Figure 2 - Protective Cap Removal**



**Figure 3 - Adjuster Shaft Operation**

6. Use an 8 mm six-point box wrench (Figure 3) to turn adjuster counterclockwise until sufficient space exists to remove brake pads. A clicking noise occurs each time adjuster turns.
7. Remove inboard and outboard brake pads (Figure 2).
8. Repeat procedure for other end of axle.
9. Check for uneven end-to-end pad wear. If wear is greater than 0.080 in. (2 mm), replace the brake pads and also service the guide pins.
10. Measure thickness of friction material on brake pads (Figure 4).
  - A = Thickness of a new pad (1.181 in.) (30 mm).
  - B = Minimum thickness of a worn pad (0.433 in.) (11 mm.); replace pads.
  - C = Thickness of a new rotor (1.77 in.) (45 mm).
  - D = Minimum thickness of a worn rotor (1.46 in.) (37 mm); replace rotor.



**Figure 4 - Brake Pad and Rotor Wear Measurement**

11. If overall thickness of either brake pad is less than 0.433 in. (11 mm), replace both brake pads.
12. If difference of inboard and outboard pad thickness is greater than 0.119 in. (3 mm), caliper may not be sliding freely on guide pins, replace the brake pads and service the guide pins.

### Brake Rotor Inspection

1. Measure thickness of brake rotor at thinnest point. Avoid measuring near edge of rotor as a burr may result in inaccurate measurement.
2. Replace rotor if thickness is less than 1.46 in. (37 mm).
3. Check rotor for grooves and cracks (Figure 5).

### Important!

**In case of surface conditions A through C, the rotor is still usable until reaching the minimum acceptable thickness of 1.46 in. (37 mm).**

a = Pad contact area.

A = Small cracks that spread across the surface are acceptable.

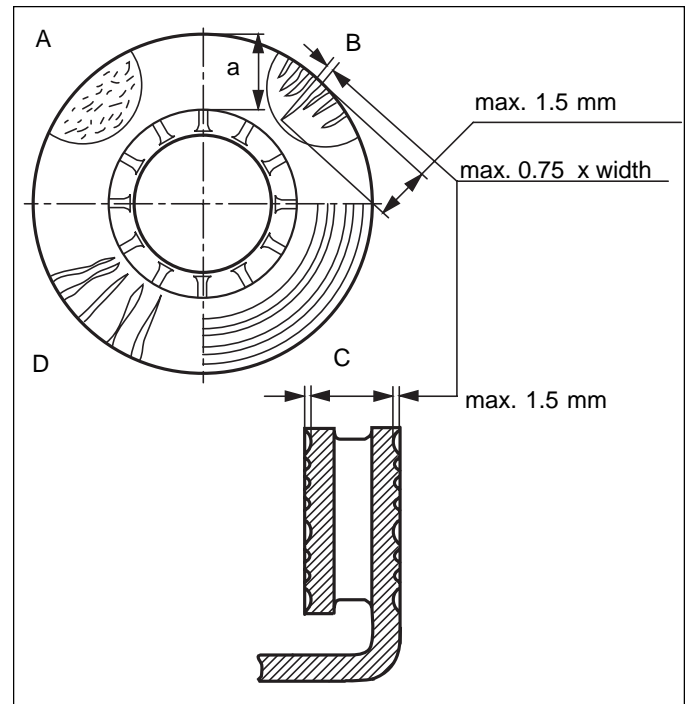
B = Cracks less than 0.060 in. (1.5 mm) deep or wide and are running in a radial direction are acceptable.

C = Grooves (circumferential) less than 0.060 in. (1.5 mm) wide are acceptable.

D = Cracks in the vanes are not allowed; replace the rotor.

### Grinding

Grinding the brake rotor is permissible, within the tolerances shown below, as necessary to increase brake pad contact area by removing severe grooving.



**Figure 5 - Rotor Inspection**

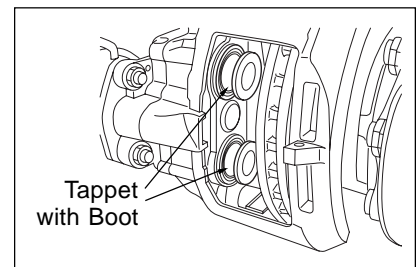
### WARNING!

**When grinding, the minimum rotor thickness must be at least 1.535 to 1.575 in. (39 to 40 mm). Check vehicle manufacturer's recommendations for grinding. Failure to comply may result in brake failure and in serious injury or death.**

### CALIPER CHECK

1. Slide caliper back and forth on guide pins. Caliper should move freely. If caliper does not move freely, service guide pins.

2. Inspect outer boot and rubber bushing of fixed guide pin for wear or damage. Replace as necessary.



**FIGURE 6 - Tappet Boot Inspection**

### BRAKE PAD INSTALLATION

#### Important!

*Always replace brake pads as an axle set. Use only Bendix replacement parts.*

*Before installing the brake pads, use the adjuster and fully retract the tappets to provide adequate clearance.*

1. Clean pad abutments.

2. Install the pad retaining springs(2) onto the brake pads(1) by inserting one end of the spring onto the lug at the top of the brake pad (See Figure 7). Carefully apply enough force to permit the second lug to fully engage, taking care to keep fingers etc. away from the spring as it seats.
3. Pull caliper fully outward and install outboard pad.
4. Push caliper fully inward and install inboard pad.
5. To reinstall wear indicators (if used): Insert the wear sensors into position in the new brake pads. Route the sensor cable through the cable protection plate channel and secure the plate with the mounting hardware retained at disassembly.

### Clearance Check and Adjustment (Figure 8)

1. Press inboard pad away from tappets.
2. Set running clearance between inner brake pad and tappets to between 0.020 and 0.028 in. (0.5 and 0.7 mm).
3. Insert 0.28 in. (0.7 mm) thickness gauge between tappet and inboard pad backplate (Figure 8).
4. Use an 8 mm six-point box wrench to turn adjuster shaft clockwise until achieving proper running clearance (Figure 9).
5. Select correct replacement adjuster cap from those supplied with the kit. Lightly grease adjuster cap with Renolit HLT2 white grease (part number II14525) and install cap included in kit into adjuster cover.
6. Push pad retainer into groove of caliper.
7. Press down on pad retainer with a flathead screwdriver to properly position it for pad retainer pin.
8. Insert pad retainer pin.
9. Fit washer and then spring clip onto pad retainer pin (Figure 1).
10. Apply and release brake. Hub should turn easily by hand after applying and releasing brake.
11. Re-check running clearance. Readjust if necessary.
12. Remount wheel.

### WARNING!

The brake pads and rotor must be maintained within the recommended wear limits. Failure to monitor wear and replace the brake pads and rotor when required may result in diminished brake performance.



Figure 7 - Pad Retaining Spring Installation

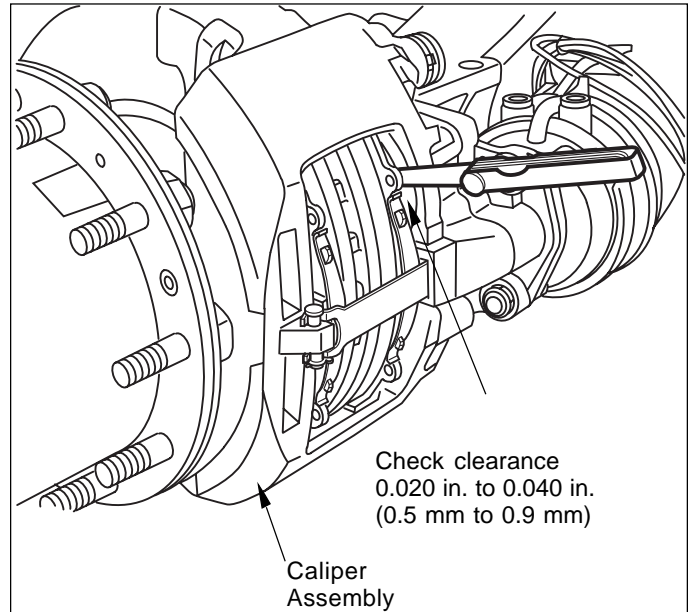


Figure 8 - Running Clearance Check

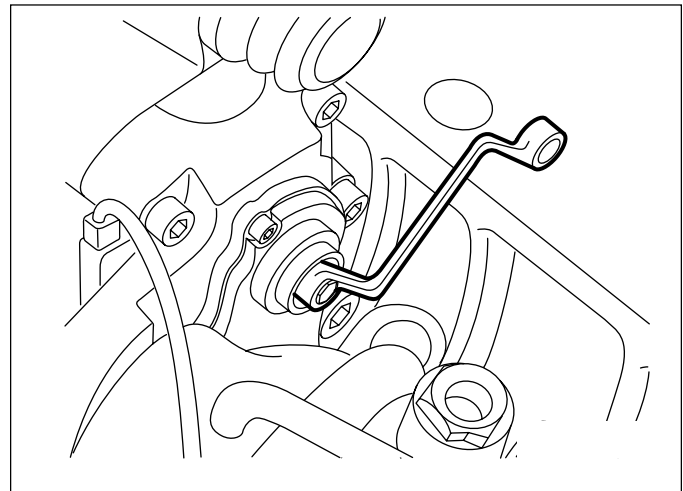


Figure 9 - Running Clearance Adjustment

